

## JWE CSDM 25

### Combination Scalding/Dehairing Machine

The CSDM 25 machine from JWE-Baumann allows automatic control of the scalding and dehairing process.

### INCREASE EFFICIENCY AND REDUCE COSTS

Combination Scalding/Dehairing Machines (CSDM) are designed to quickly and efficiently remove hair from up to 15 hogs per hour.

The CSDM 25 machine is designed to handle hogs ranging in size from 100-500 lbs with an average scald/dehair time of 2-8 minutes per hog.

The control panel allows for the automatic control of opening and closing of the lid, and the time of operation. Additionally, the temperature is automatically controlled.

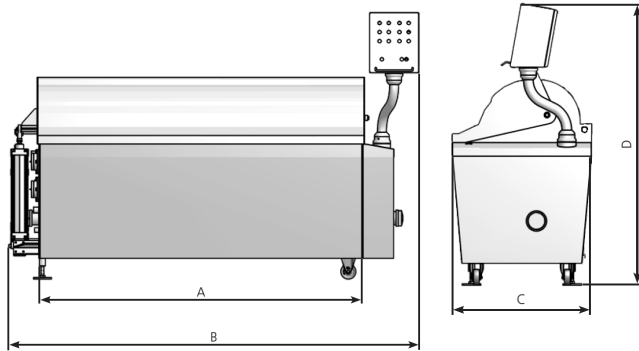

#### Product Specifications

ELECTRICAL SETUP	230V/3phase/60Hz (50 amp)
ROLLER MOTOR	4-hp
HEATING CAPACITY	12kW
HOG WEIGHT MAX	100-500 lbs.
WATER VOLUME	~70 gallons
AIR REQUIREMENT	90PSI

#### Dimensions

A	74.8-in. (1900mm)
B	97.05-in. (2465mm)
C	33.86-in. (860mm)
D	68.31-in. (1735mm)

### STANDARD FEATURES:

- » Stainless steel construction
- » Ergonomically positioned, swivel control panel
- » Water outlet on both sides
- » Pneumatically controlled discharge arm
- » Pneumatically controlled cover
- » Two galvanized dehairing rolls
- » Standard 12kW heating capacity
- » Casters on operator end for mobility